

NXWBS1

Wall mount bracket



Technical data

Mechanical

Bracket for NTC, NXM36, NXM, NTM, NXW, NTW

Bracket for MVX, MVXT, MVXHD

Suitable for: NXCOL, NXCW

Made of AISI 316L electropolished stainless steel

Load rating: 45kg (99lb)

Dimensions: 371×186mm (14.6×7.3in)

Unit weight: 2.5kg (5.5lb)

Part number

NXWBS1 AISI 316L stainless steel wall bracket with joint

Package

Model Number	Weight	Dimensions (WxHxL)	
NXWBS1	2.8kg (6.2lb)	16×18.5×46cm (6.3×7.3×18.1in)	8

Technical drawings

The indicated measurements are expressed in millimetres.

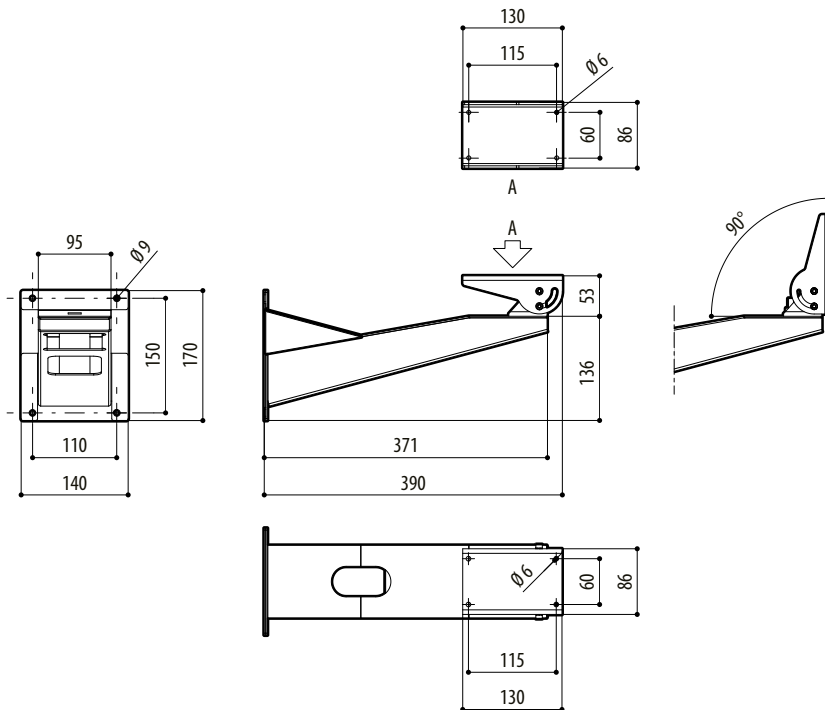

NXWBS1

Support

Learn more and find additional documentation at pelco.com or email support@pelco.com for specific product support.

© 2025, Pelco Inc. All rights reserved. MOTOROLA, MOTO, MOTOROLA SOLUTIONS, and the Stylized M Logo are trademarks or registered trademarks of Motorola Trademark Holdings, LLC and are used under license. Pelco, the Pelco logo, and other trademarks associated with Pelco products referred to in this publication are trademarks of Pelco, Inc. or its affiliates. All other product names and services are the property of their respective companies. Product specifications and availability are subject to change without notice.

JAN 2026 | | REV 1

PELCO