

# Esprit Anti-Corrosion Fixed Camera



Compliant with NDAA 2019  
Section 889

The Esprit Anti-Corrosion Fixed is a stainless steel fixed camera with exceptional resistance to corrosion, designed to guarantee efficient video security in offshore/onshore marine environments and in ports and roadways. With 40x zoom and full 1080p resolution, the Esprit Anti-Corrosion Fixed camera offers exceptional image quality while tracking objects in motion and in variable lighting conditions thanks to wide dynamic range and low light compensation. In addition, the Esprit Anti-Corrosion Fixed camera offers AISI 316L construction, with IP66/IP67/IP68/IP69 certifications, NEMA Type 4X and 6P ratings and Lloyd's Register Type Approval, among other environmental certifications, that ensure sites are protected even in wet and treacherous conditions.

2 MP



## Features

### RUGGED CONSTRUCTION

AISI 316L stainless steel offers maximum corrosion resistance.

### WIDE DYNAMIC RANGE & LOW LIGHT COMPENSATION

Offers excellent image detail in contrasting light and shadows.

### HIGH-TEMPERATURE RANGE

Optimized to operate reliably even at increased temperature variances: from -40°C (-40°F) up to +65°C (+149°F).

### ONVIF® COMPLIANT

ONVIF Profile G, M, S and T compliance allows for easy integration with existing ONVIF infrastructures. Integrates with Pelco VideoXpert and other leading video management systems.

\*ONVIF is a trademark of Onvif, Inc.

### WEATHER RESISTANT

Rated NEMA Type 4X/6P and IP66/67/68/69 for water, corrosion and dust resistance.

### RAILWAY COMPLIANCE

Complies with the standard for railway applications.

### LLOYD'S REGISTER MARINE TYPE APPROVAL

Obtained Lloyd's Register Marine Type Approval for the maritime and shipping sector.

### PEACE OF MIND

3-year limited warranty. 5-year extended warranty is available.

**PELCO®**

# Specifications

## Image Performance 2 mp

Image Sensor	1/2.8" progressive scan CMOS, 2 MP
Active Pixels (H x V)	1937 (H) x 1097 (V) = 2.2M Pixels
Imaging Area (H x V)	5.568 mm (H) x 3.132 mm (V); 0.219 " (H) x 0.123 " (V)
Minimum Illumination	0.03 lux (F/1.6) in color mode; 0.02 lux (F/1.6) in monochrome
Dynamic Range	120 dB
Image Rate	Up to 60 fps
Aspect Ratio (Resolution Scaling)	Down to (16:9) 384x216 or (5:4) 320x256
3D Noise Reduction Filter	Yes

## Lens

Lens	4.25 to 170 mm, F/1.6 – F/4.95, autofocus	
Angle of View	Horizontal	66.35° - 1.9°
	Vertical	39.99° - 1.11°
Zoom	Up to 40x	

## Image Control

Video Compression	H.264 and H.265 Pelco Smart Compression, Motion JPEG
Streaming	Multi-stream H.264, Multi-stream H.265, Motion JPEG
Motion Detection	Pixel motion: Selectable sensitivity and threshold. Classified object detection
Electronic Shutter Control	Automatic, Manual (1/1 to 1/10,000 sec)
Iris Control	Automatic, Open, Closed
Day/Night Control	Automatic, Manual
Flicker Control	60 Hz, 50 Hz
White Balance	Automatic, Manual
Backlight Compensation	On/Off
Privacy Zones	3D, up to 64 zones
Presets	500 named presets
Tours	No
Electronic Image Stabilization	Yes
Digital Defog	Adjustable/Off

## Network

Network	100 BASE-TX
---------	-------------

## Network

Cabling Type	CAT5e/CAT6 shielded (STP) Ethernet cable is required to fully comply with EMC regulatory standards
Connector	RJ-45
ONVIF	ONVIF compliance Profile G, Profile M, Profile S, and Profile T ( <a href="http://www.onvif.org">www.onvif.org</a> )
Security	Password protection, HTTPS encryption, digest authentication, WS authentication, user access log, 802.1x port based authentication. Signed and encrypted firmware. FIPS 140-2 Level 1
Protocols	IPv6, IPv4, HTTP, HTTPS, SOAP, DNS, NTP, RTSP, RTCP, RTP, TCP, UDP, IGMPv3, ICMP, DHCP, Zeroconf, ARP, HSTS, QoS, DSCP
Streaming Protocols	RTP/UDP, RTP/UDP multicast, RTP/RTSP/TCP, RTP/RTSP/HTTP/TCP, RTP/RTSP/HTTPS/TCP, HTTP, SRTP
Device Management Protocols	SNMP v2c, SNMP v3

## Peripherals

Audio Input/Output	None
External I/O Terminals	2 Digital Output (optional)
Onboard Storage	Pre-installed 128 GBytes storage

## Mechanical

Camera Weight (fastening support included)	5.1 kg; 11.2 lb
Extra Clear Glass Window	3 mm thick (0.12")
Polycarbonate Window (optional)	3 mm thick (0.12")
Construction	AISI 316L stainless steel
Mounting configuration	Wall, Parapet and Ceiling mount

## Electrical

Power Consumption	21W	
Power Source/Current Consumption	External Power	24 VAC, 1.32A, 50/60 Hz 24 VDC, 0.9A
	PoE	PoE+ (IEEE 802.3 at)
Power/Signal Connector	26 AWG to 18 AWG	
RTC Battery Backup	None	

## Environmental

Operating Temperature	From -40°C (-40°F) up to +65°C (149°F) Temperature test complies with NEMA-TS 2-2003 (R2008) par. 2.1.5.1, test profile fig. 2-1 (from -34°C (-29.2°F) to +74°C (165.2°F))
Storage Temperature	-40 °C to +70 °C (-40 °F to 158 °F)
Humidity	5% - 95% non-condensing
Housing Climate Control	Built-in heater and fan
Cold Start	Up to 60 minute startup delay at temperature lower than -10 °C (14 °F)

## Certifications

Certifications/Directives	UL, cUL, CE, UKCA, ROHS, LR, RCM, KC
Safety	UL 62368-1, CSA 62368-1, IEC/EN 62368-1, IS13252(PART 1):2010/IEC60950-1:2005
Environmental and Performance	UL/CSA/IEC 60950-22, IEC 60529 IP66, IP67, IP68, IP69 Weather Rating, IEC 60068-2-1, IEC 60068-2-2, IEC 60068-2-6, IEC 60068-2-30, IEC 60068-2-14, NEMA TS 2 para 2.2.7 - 2.2.9, Type 4X and 6P, MIL-STD-810-H
Electromagnetic Emissions	FCC Part 15 Subpart B Class A, IC ICES-003 Class A, EN 55032 Class A, EN 61000-6-4, EN 61000-3-2, EN 61000-3-3, EN 50121-4
Electromagnetic Immunity	EN 55035, EN 50121-4 only for 24 VDC/VAC
Warranty	3-year limited warranty. 5-year extended warranty is available.
Railway Applications	Compliance to railway application standard: EN50121-4 (only with 24 VAC or 24 VDC power supply)
Marine Applications	Lloyd's Register Marine Type Approval: Test Specification Number 1 (ENV1, ENV2, ENV3, ENV5) Electromagnetic compatibility: EN60945 Environmental: EN60068-2-52, IEC 60068-2-78 Tested at 70°C (158°F) for 16 hours in compliance with EN60068-2-2

# Analytics Specifications

## Supported Analytics Events\*

Objects in Area	The event is triggered when the selected object type moves into the region of interest.
Object Loitering	The event is triggered when the selected object type moves into the region of interest, then stays for an extended amount of time.
Objects Crossing Beam	The event is triggered when the specified number of objects have crossed the directional beam that is configured over the camera's field of view. The beam can be unidirectional or bidirectional.
Object Appears or Enters Area	The event is triggered by each object that enters the region of interest and can also be used to count objects.
Object Not Present in Area	The event is triggered when no objects are present in the region of interest.
Objects Enter Area	The event is triggered when the specified number of objects have entered the region of interest.
Objects Leave Area	The event is triggered when the specified number of objects have left the region of interest.
Object Stops in Area	The event is triggered when an object moves into a region of interest and then stops moving for the specified threshold time.
Direction Violated	The event is triggered when an object moves in the prohibited direction of travel.
Sabotage Detection	The event is triggered when the scene unexpectedly changes.

\*Pelco Smart Analytics powered by Motorola Solutions.

## Pelco Elevate Supported Features

Image Health	Detects incremental changes in the cameras view, such as position shifts or obstructions. Notifies users through ONVIF conformant events and summarized email reports.
Firmware Management	Schedule and deploy automatic firmware updates to multiple cameras, or update individual cameras on-demand.

# Outline Dimensions

## Esprit Anticorrosion Enhanced 2MPX40 Fixed

(Esprit Anti-Corrosion Enhanced 1 Series, 2MP 40x Zoom, Fixed Bullet, 24V/poe+)

[X.XX]	INCHES
X.X	MM

### Wall Mount

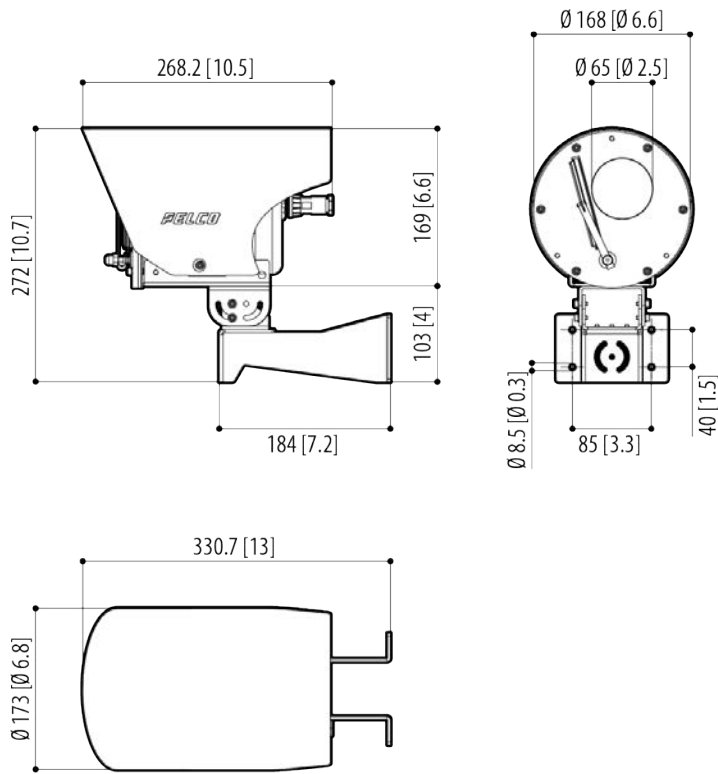

# Parapet Mount

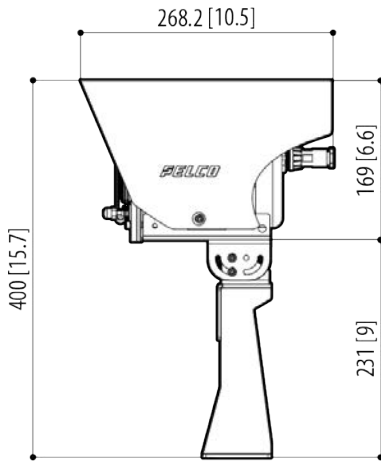
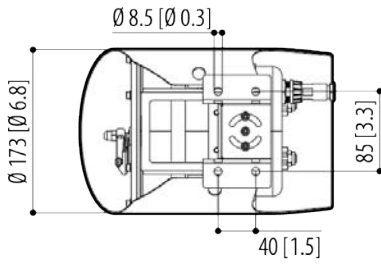

# Ceiling Mount

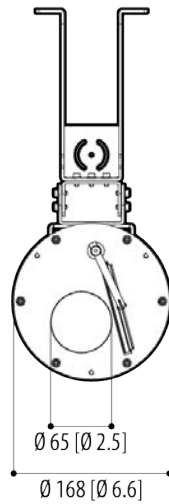
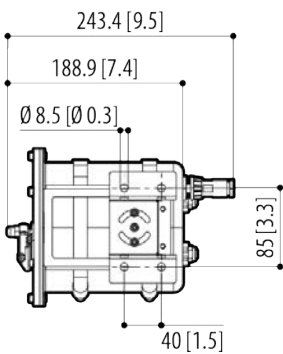
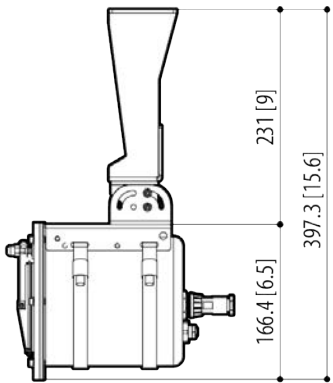

# Ordering Information

## ESPRIT ANTI-CORROSION FIXED CAMERA

Display Part Number	Extra Clear Glass Window	Polycarbonate Window	Wiper	2 Digital Outputs
ESSE1-2X40-SBT-PAP		✓		
ESSE1-2X40-SBT-PA	✓			
ESSE1-2X40-SBT-PAW	✓		✓	✓

## ESPRIT ANTI-CORROSION FIXED ACCESSORIES

Accessory	Description
UEAP	Pole adaptor, stainless steel AISI 316L
UEAC	Corner adaptor, SS AISI 316L
UEAW	Counter-plate, stainless steel AISI 316L
WASPT0V5L5M00	Washer 5l, 5m, 230VAC-24VAC-120VAC
WASPT0V23L11M00	Washer 23l, 11m, 230Vac-24VAC-120VAC
WASPT1V23L30M00	Washer 23l, 30m, water float, 230VAC
WASPT3V23L30M00	Washer 23l, 30m, water float, 120VAC
COMB100A	Comm. box, w PS & Switch, 220-230VAC
COMB200A	Comm. box, w PS & Switch, 24VAC
COMB300A	Comm. box, w PS & Switch, 120-127VAC
WASNX1V10L20M00	Tank 10l (2.6gal) with integrated manual pump, controlled by solenoid valve, IN 230 Vac, delivery head up to 30m (98ft), with 20m (66ft) antistatic water delivery pipe
WASNX2V10L20M00	Tank 10l (2.6gal) with integrated manual pump, controlled by solenoid valve, IN 24 Vac, delivery head up to 30m (98ft), with 20m (66ft) antistatic water delivery pipe
WASNX3V10L20M00	Tank 10l (2.6gal) with integrated manual pump, controlled by solenoid valve, IN 120 Vac, delivery head up to 30m (98ft), with 20m (66ft) antistatic water delivery pipe

# Support

Learn more and find additional documentation at [pelco.com](https://pelco.com) or email [support@pelco.com](mailto:support@pelco.com) for specific product support.